

Features

- Receiver applications
 - ✦ Dual 1310 nm GaAs PIN receivers
- 10km reach
- 1250 or 1062.5 Mb/s data rate
- Dual Optical Receiver unit with independent
- Meet SFF MSA with duplex LC receptacle
- Hot-pluggable
- 2x10 SFP MSA compliant package
- Metal enclosure for lower EMI
- +3.3V Single power supply
- Operating case temperature:
 - Standard : 0 to +70°C
- Qualified to meet the intent of Bellcore reliability practices
- LVPECL logic interface simplifies interface to external circuitry
- LVTTTL logic Signal level RX LOS
- With pull de-latch
- Compliant with UL standards

Application

- 1250 Mb/s Gigabit Ethernet data links
- 1062.5 Mb/s Fibre Channel data links
- Data storage networks
- Host adapters
- Telecom switches
- ATM
- SONET/SDH
- Switches
- Routers
- Hubs

General

The SFP/LC Gigabit Ethernet dual optical receiver is intended for 10km reach service in 1250 Mb/s or 1062.5 Mb/s 1310 nm single mode high-speed LAN and SAN data communications equipment where low-cost, extraordinary performance and reliability are essential. It meets the transmit requirements of IEEE802.3z 1000 BASE-SX and FC-PI-2-100-M5/M6-SN-I. It consumes low power, operates from a 3.3 volt DC power supply and is offered in the 0°C to +70°C commercial temperature ranges. The industry standard 2x10 small form pluggable (SFP) package is fabricated with a rugged die cast metal housing and cage assembly. The Rx_LOS function monitors the incoming optical signal. The 50 Ohm differential AC coupled Rx_data interfaces are LVPECL compatible.

DUAL RECEIVER BLOCK DIAGRAM

The dual receivers consist of high-speed GaAs PIN photodiodes and transimpedance preamplifiers mounted in an optical subassembly (ROSA), which are mated to the ports of the fiber optic LC duplex receptacle. The output of the PD drives the post-amplification, quantizing, and optical signal detection circuits. The receiver is equipped with the Rx_LOS (Loss of Signal) monitoring function.

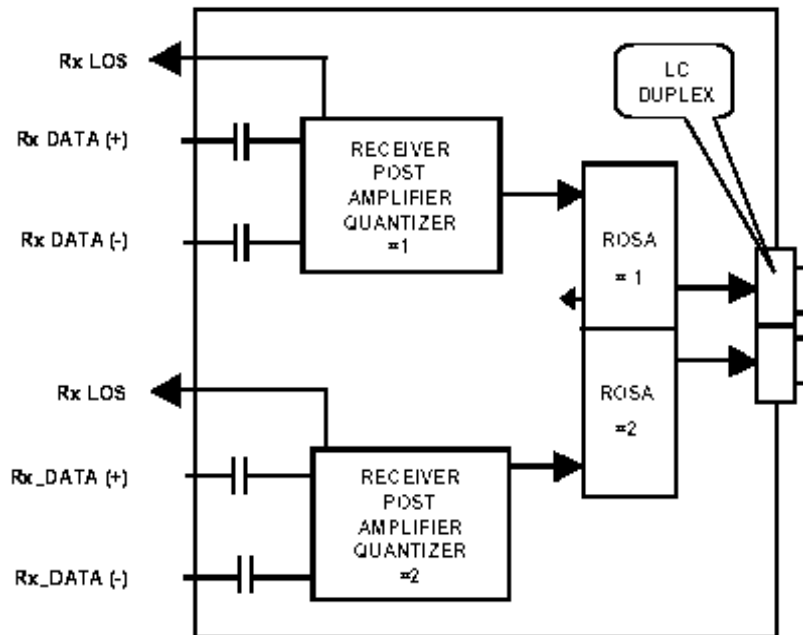

Receiver Section

The receiver section uses a hermetic packaged front end receiver (InGaAs PIN and preamplifier). The postamplifier is ac coupled to preamplifier through a capacitor and a low pass filter. The Rx_LOS (Loss of Signal) is an open collector LVTTTL monitor port. It switches state based on the received optical input signal level that passes through the photo detector (PD), post amplifier and quantizer. If the received signal is above the Rx threshold, then Rx_LOS is set LOW indicating normal operation. If the received signal is below the Rx threshold, then Rx_LOS is set HIGH indicating a possible broken fiber, unplugged connector or low Tx signal from the host. The Rx_LOS pin requires an external 4.7K to 10 K Ohm pull-up resistor.

EEPROM Section

The optical receiver contains an EEPROM. It provides access to sophisticated identification information that describes the receiver's capabilities, standard interfaces, manufacturer, and other information. The serial interface uses the 2-wire serial CMOS EEPROM protocol defined for the ATMEL AT24C01A/02/04 family of components. When the serial protocol is activated, the host generates the serial clock signal (SCL, Mod Def 1). The positive edge clocks data into those segments of the EEPROM that are not write protected within the SFP receiver. The negative edge clocks data from the SFP receiver. The serial data signal (SDA, Mod Def 2) is bi-directional for serial data transfer. The host uses SDA in conjunction with SCL to mark the start and end of serial protocol activation. The memories are organized as a series of 8-bit data words that can be addressed individually or sequentially.

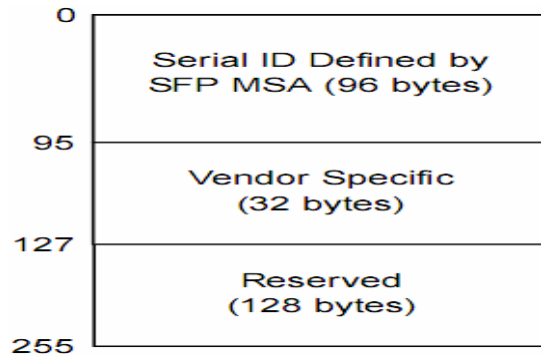
Memory Map:

2 wire address 1010000x (A0h)

Performance Specifications**Table 1. Absolute Maximum Ratings**

Parameter	Symbol	Min	Max	Unit	
Storage Temperature	Tst	-40	+85	°C	
Operating Temperature	To	SSFP3152-RR	0	+70	°C
Input Voltage	-	GND	Vcc	V	
Power Supply Voltage	Vcc-Vee	-0.5	+3.6	V	

Note: Stress in excess of maximum absolute ratings can cause permanent damage to the module

Table 2. Operating Environment

Parameter	Symbol	Min	Max	Unit	
Power Supply Voltage	Vcc	+3.1	+3.5	V	
Ambient Operating Temperature	TA	SSFP3152-RR	0	+70	°C

Table 3. Receiver optical-electrical characteristics (TA = 25 °C)

Parameter	Symbol	Min	Typ	Max	Unit	Note
Operate Wavelength	λ_p	1260	-	1620	nm	-
Sensitivity	Pr	-	-	-22	dBm	1
Saturation	Ps	-3	-	-	dBm	1
LOS Asserted	-	-35	-	-	dBm	High Level: Alarm
LOS De-Assert	-	-	-	-22	dBm	
LOS Hysteresis	-	-	1.5	-	dB	
LOS LOW voltage	VLout	-	-	0.8	V	-
LOS HIGH voltage	VHout	2.4	-	-	V	-
Data Output Rise / Fall Time	tr / tf	-	-	0.28	ns	20-80%
Rx Differential Load Impedance	ZLOAD	-	100	-	Ohms	-
Data Outputs Voltage	Vpp	400	800	1000	mV	2

Notes:

1. Minimum Sensitivity and saturation levels for a $2^7 - 1$ PRBS test pattern @1.25Gbit/s
2. Internally AC coupled

Table 4.Receiver Logic

Parameter	Function	Logic State	Logic Stype	Min	Max	Units
Rx_LOS	LOSS OF SIGNAL	HIGH	LVTTTL	2.4	VCC+0.3	V
Rx_LOS	NORMAL	LOW	LVTTTL	0	0.8	V

Pin Definition

Pin Out Diagram

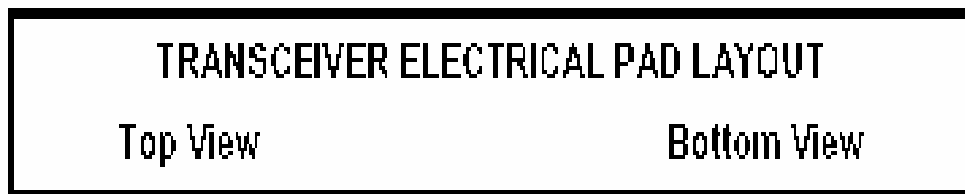
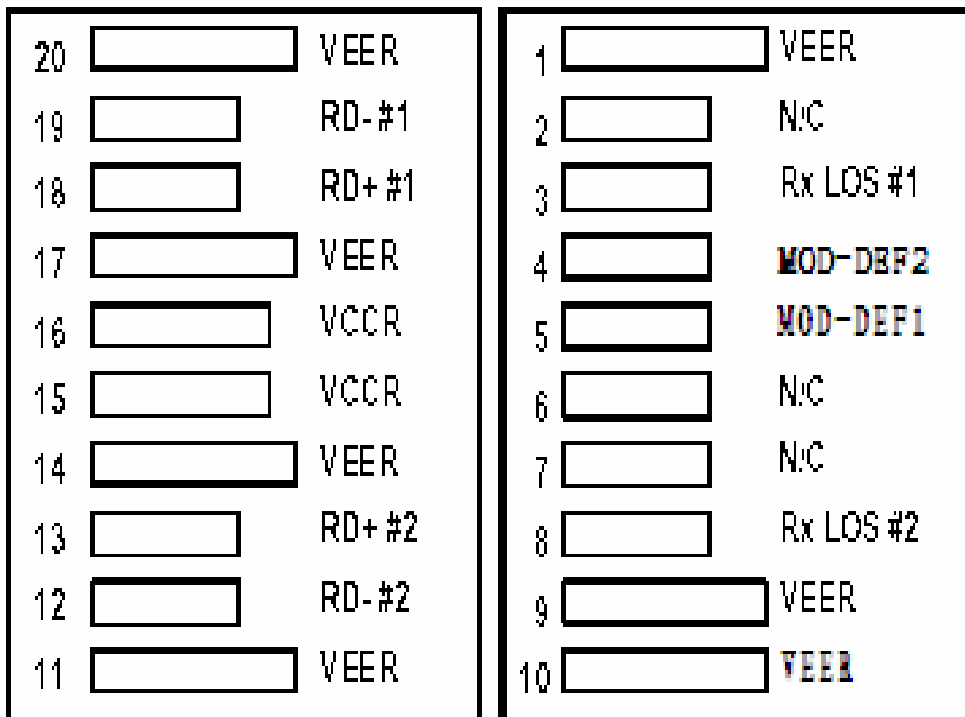

Table 5.Pin Function Definitions

Pin#	Name	Description	Notes
1	VeeR	Receiver Ground	Note 3
2	N/C	Internally Connected - Do Not Use This Pin	-
3	Rx LOS #1	Rx LOSS OF SIGNAL LOW = Normal Operation; HIGH = Receiver OFF	Note 1
4	MOD-DEF2	Module Definition 2	Note5, 2 wire serial ID interface
5	MOD-DEF1	Module Definition 1	Note5, 2 wire serial ID interface
6	N/C	Internally Connected - Do Not Use This Pin	-
7	N/C	Internally Connected - Do Not Use This Pin	-
8	Rx LOS #2	Rx LOSS OF SIGNAL LOW = Normal Operation; HIGH = Receiver OFF	Note 1
9	VeeR	Receiver Ground	Note 3
10	VeeR	Receiver Ground	Note 3
11	VeeR	Receiver Ground	Note 3
12	RD- #2	Rx_Data Output (Inverted)	Note 2
13	RD+ #2	Rx_Data Output (Non Inverted)	Note 2
14	VeeR	Receiver Ground	Note 3
15	VccR #2	Receiver Power	Note 4, 3.3V± 5%
16	VccR #1	Transmitter Power	Note 4, 3.3V± 5%
17	VeeR	Receiver Ground	Note 3
18	RD+ #1	Rx_Data Output (Non Inverted)	Note 2
19	RD- #1	Rx_Data Output (Inverted)	Note 2
20	VeeR	Receiver Ground	Note 3

Note:

- 1. The uncommitted Rx_LOS LVTTTL monitor pins each require a pull up resistor of 4.7K to 10K Ohms. LOS (Loss of Signal) is an open collector/drain output, which should be pulled up with a 4.7K – 10KΩ resistor. Pull up voltage between 2.0V and VccR+0.3V. When high, this output indicates the received optical power is below the worst-case receiver sensitivity(as defined by the standard in use). Low indicates normal operation. In the low state, the output will be pulled to < 0.8V.**
- 2. RD-/+:** These are the differential receiver outputs. They are AC coupled 100Ω differential lines which should be terminated with 100Ω (differential) at the user SERDES. The AC coupling is done inside the module and is thus not required on the host board.

3. VeeR may be internally connected within the SFP module.
4. VccR are the receiver and transmitter power supplies. They are defined as 3.3V ±5% at the SFP connector pin. Maximum supply current is 300mA. Recommended host board power supply filtering is shown below. Inductors with DC resistance of less than 1Ω should be used in order to maintain the required voltage at the SFP input pin with 3.3V supply voltage. When the recommended supply filtering network is used, hotplugging of the SFP transceiver module will result in an inrush current of no more than 30 mA greater than the steady state value. VccR may be internally connected within the SFP transceiver module.
5. Mod-Def 0,1,2. These are the module definition pins. They should be pulled up with a 4.7K – 10KΩ resistor on the host board. The pull-up voltage shall be VccR. Mod-Def 0 is grounded by the module to indicate that the module is present Mod-Def 1 is the clock line of two wire serial interface for serial ID Mod-Def 2 is the data line of two wire serial interface for serial ID

Package information

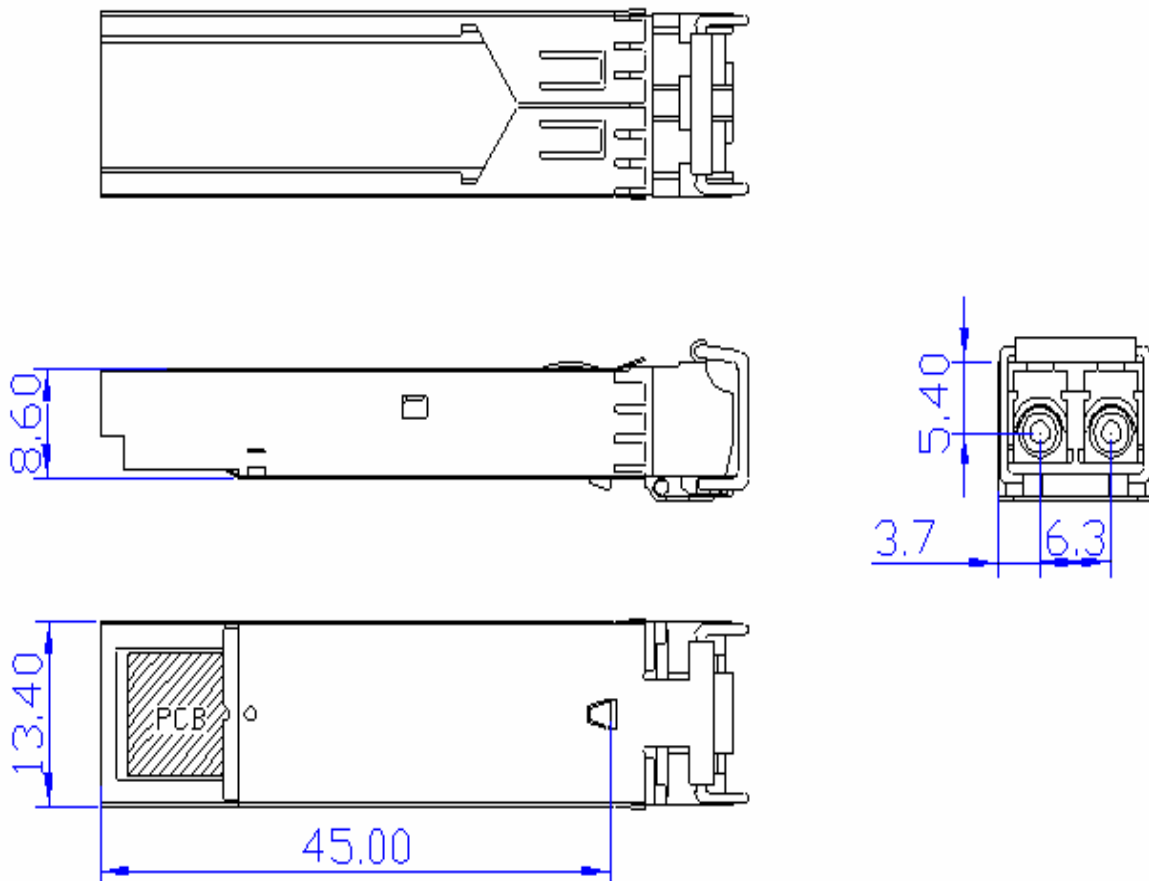

Unit: mm

Recommended Circuit

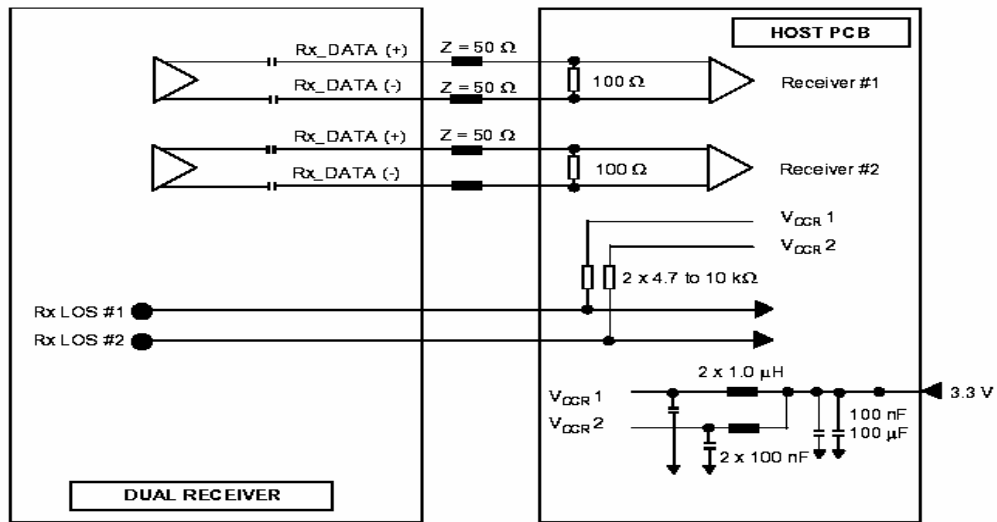

Note: 4.7K ohms < RES < 10K ohms

Recommended Board Layout Hole Pattern

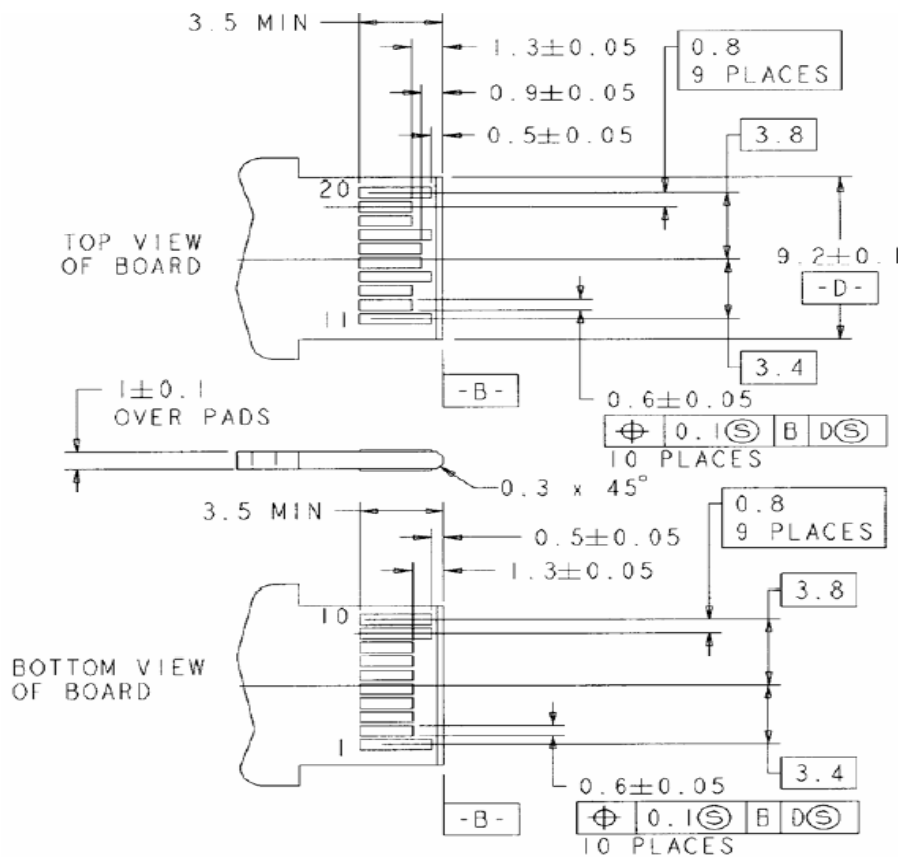

Obtaining Document

Please visit our website:

[Http://www.staropto.com](http://www.staropto.com)

Ordering Information

S S FP 3 1 5 2 - RR

Manufact -urer	Mode Type	Package Type	Wave length (nm)	LD Type	Data Rate (Mb/s)	Package Type	
S: Star opto	S: Single Mode	FP: small form pluggable (SFP) package	3: 1310	1: FP	5: 1250	2: Without DDM	RR: Dual Optical Receiver