

Features

- Transceiver unit with independent
 - ✦ CWDM Laser diode transmitter
 - ✦ InGaAs PIN photodiode receiver
- Meet SFP MSA and SFF-8472 with duplex LC receptacle
- Operating data rate up to 2500Mbps
- Digital diagnostic monitoring
- Hot-pluggable
- Metal enclosure for lower EMI
- +3.3V Single power supply
- Operating case temperature:
 - Standard : 0 to +70°C
- Qualified to meet the intent of Bellcore reliability practices
- LVPECL logic interface simplifies interface to external circuitry
- LVTTTL logic Signal level RX LOS
- With pull de-latch
- Compliant ROHS and lead free
- Compliant with UL standard



Application

- ATM
- SONET/SDH
- Ethernet
- Switches
- Routers
- Hubs

General

The optical transceiver is compliant with the Small Form- Factor Pluggable (SFP) Multi-Source Agreement (MSA) and SFF-8472. It offers previously unavailable system cost, upgrade, and reliability benefits by virtue of being hot-pluggable.

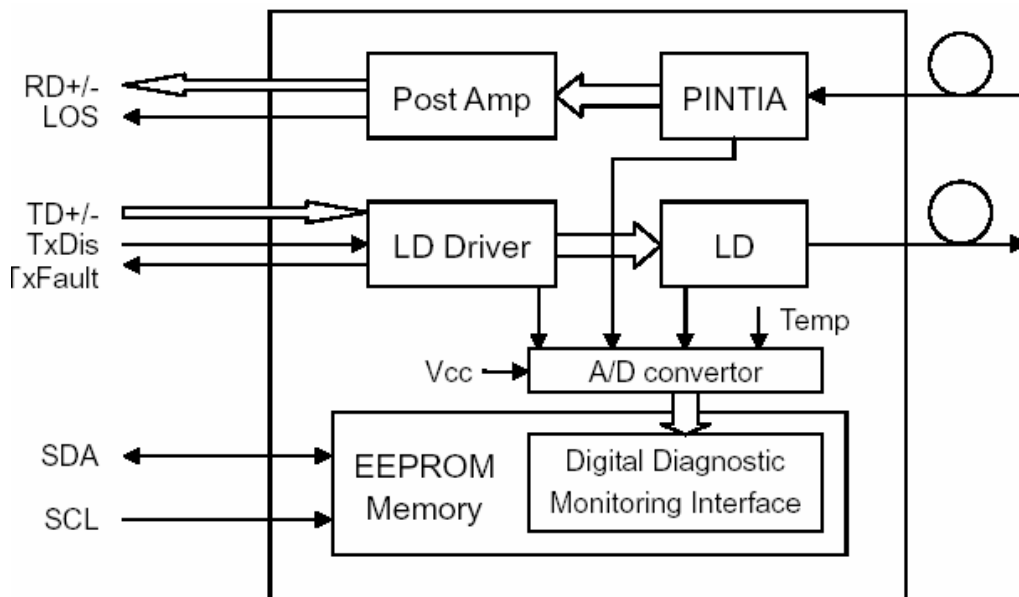

Transmitter Section

Transmitter is designed for single mode fiber and operates at CWDM wavelength of 1270 nm, 1290 nm, 1310 nm, 1330 nm, 1350 nm, 1370 nm, 1390 nm, 1410 nm, 1430 nm, 1450 nm, 1470 nm, 1490 nm, 1510 nm, 1530 nm, 1550 nm, 1570 nm, 1590 nm, 1610 nm. The transmitter module uses a DFB laser diode and full IEC825 and CDRH class 1 eye safety. The output power can be disabled via the single TxDis pin. Logic LVTTTL HIGH level disables the transmitter. It contains APC function, temperature compensation circuit, LVPECL data inputs ,LVTTTL Txdis input and Tx fault Output interface.

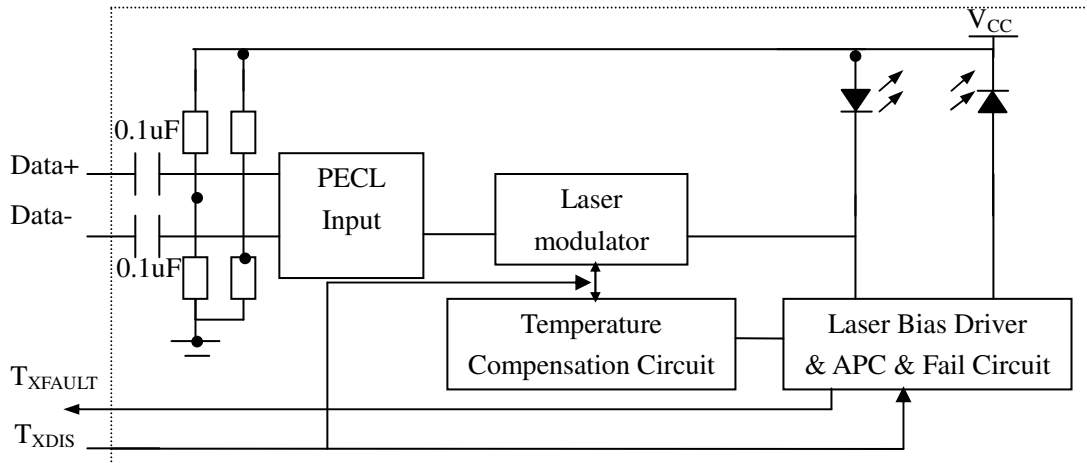

Figure1. Transmitter Block Diagram

Receiver Section

The receiver section uses a hermetic packaged front end receiver (InGaAs PIN and preamplifier). The postamplifier is ac coupled to preamplifier through a capacitor and a low pass filter. The capacitor and LPF are enough to pass the signal from 2000Mb/s to 2500Mb/s without significant distortion or performance penalty. The LPF limits the preamplifier bandwidth to improve receiver sensitivity. As the input optical is decreased, LOS will switch from low to high. As the input optical power is increased from very low levels, LOS will switch back from high to low.

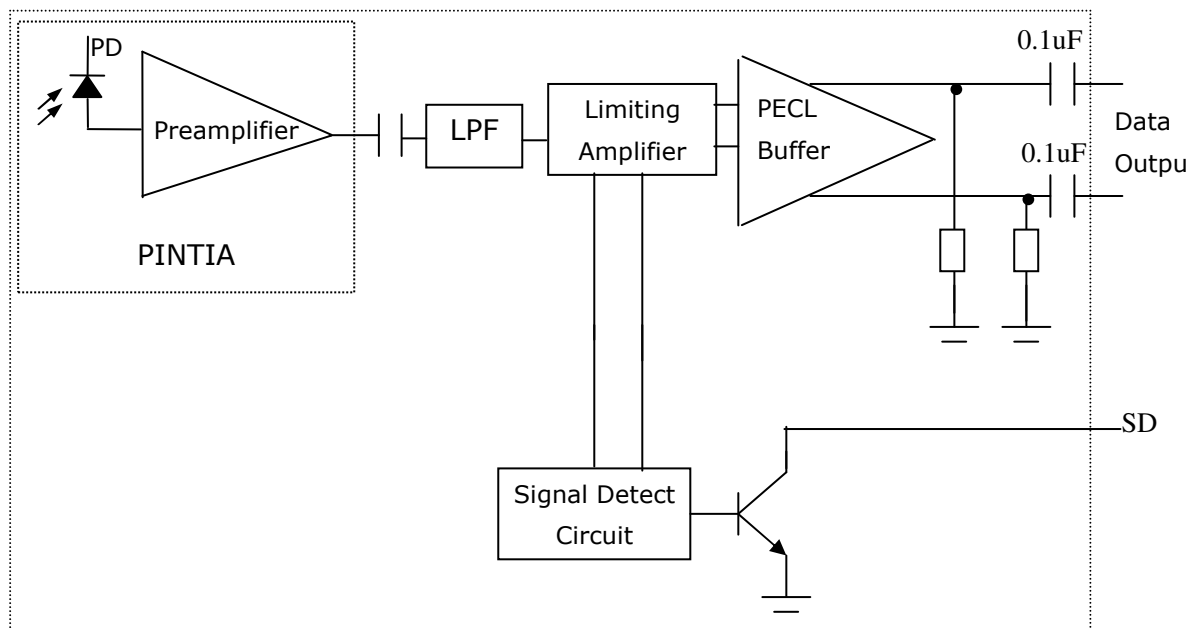

Figure2. Receiver Block Diagram

EEPROM Section

The optical transceiver contains an EEPROM. It provides access to sophisticated identification information that describes the transceiver's capabilities, standard interfaces, manufacturer, and other information.

The serial interface uses the 2-wire serial CMOS EEPROM protocol defined for the ATMEL AT24C01A/02/04 family of components. When the serial protocol is activated, the host generates the serial clock signal (SCL, Mod Def 1). The positive edge clocks data into those segments of the EEPROM that are not write protected within the SFP transceiver. The negative edge clocks data from the SFP transceiver. The serial data signal (SDA, Mod Def 2) is bi-directional for serial data transfer. The host uses SDA in conjunction with SCL to mark the start and end of serial protocol activation. The memories are organized as a series of 8-bit data words that can be addressed individually or sequentially.

The Module provides diagnostic information about the present operating conditions. The transceiver generates this diagnostic data by digitization of internal analog signals. Calibration and alarm/warning threshold data is written during device manufacture. Received power monitoring, transmitted power monitoring, bias current monitoring, supply voltage monitoring and temperature monitoring all are implemented. The diagnostic data are raw A/D values and must be converted to real world units using calibration constants stored in EEPROM locations 56 – 95 at wire serial bus address A2h. The digital diagnostic memory map specific data field define as following.

Memory Map:

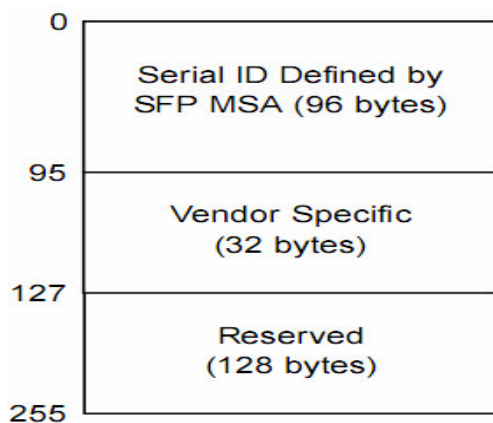

2 wire address 1010000x (A0h)

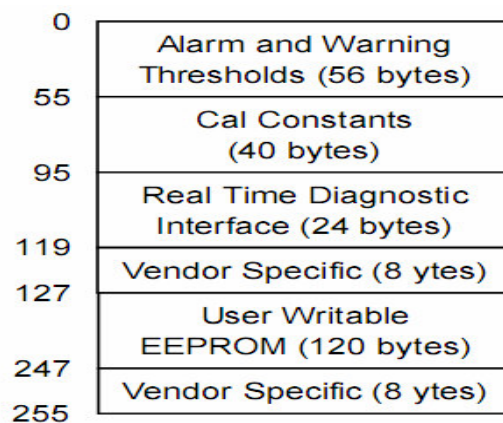

2 wire address 1010001x (A2h)

Performance Specifications

Table 1. Absolute Maximum Ratings

Parameter	Symbol	Min	Max	Unit	
Storage Temperature	Tst	-40	+85	°C	
Operating Temperature	To	SCFPxx61-33-125F	0	+70	°C
Input Voltage	-	GND	Vcc	V	
Power Supply Voltage	Vcc-Vee	-0.5	+3.6	V	

Note: Stress in excess of maximum absolute ratings can cause permanent damage to the module

Table 2. Operating Environment

Parameter	Symbol	Min	Max	Unit	
Power Supply Voltage	Vcc	+3.1	+3.5	V	
Ambient Operating Temperature	TA	SCFPxx61-33-125F	0	+70	°C

Table 3. Transmitter electrical and optical Characteristics

Parameter	Symbol	Min	Typ	Max	Unit	Note
Center Wavelength	λ_p	1263	1270	1277	nm	T=0~+70°C
		1283	1290	1297	nm	
		1303	1310	1317	nm	
		1323	1330	1337	nm	
		1343	1350	1357	nm	
		1363	1370	1377	nm	
		1383	1390	1397	nm	
		1403	1410	1417	nm	
		1423	1430	1437	nm	
		1443	1450	1457	nm	
		1463	1470	1477	nm	
		1483	1490	1497	nm	
		1503	1510	1517	nm	
		1523	1530	1537	nm	
		1543	1550	1557	nm	
		1563	1570	1577	nm	
1583	1590	1597	nm			
1603	1610	1617	nm			
Spectral Width	$\Delta\lambda$	-	-	1	nm	-
Side Mode suppression Ratio	SMSR	30	-	-	dB	-
Average Optical Output Power	Po	-2	-	+3	dBm	-
Extinction Ratio	EXT	8.2	-	-	dB	-
Input Differential Impedance	Z _{IN}	90	100	110	Ω	
Transmitter disable Voltage	V _D	2	-	Vcc	V	-
Transmitter Enable Voltage	V _{EN}	0	-	0.8	V	-
Power supply Current	I _{CC}	-	70	180	mA	1
Data Input Voltage	V _{PP}	300	-	1600	mV	-
Output Eye Diagram	Compliant with ITU-T.G957					

Table 4.Receiver optical-electrical characteristics

Parameter	Symbol	Min	Typ	Max	Unit	Note
Operate wavelength	-	1260	-	1620	nm	-
Sensitivity	sen	-	-	-20	dBm	2
Saturation	Ps	-3	-	-	dBm	2
LOS Asserted	-	-35	-	-	dBm	High Level: Alarm
LOS De-Assert	-	-	-	-20	dBm	
LOS Hysteresis	-	0.5	2	-	dB	

LOS LOW voltage	VLout	-	-	0.8	V	-
LOS HIGH voltage	VHout	2.0	-	-	V	-
Power Supply Current	Icc	-	80	170	mA	1
Data Outputs Voltage	Vpp	400	800	1000	mV	-

Notes:

1. The current excludes the output load current.
2. Minimum Sensitivity and saturation levels for a 2²³-1 PRBS test pattern @2.5Gbit/s

Pin Definition

Pin Out Diagram

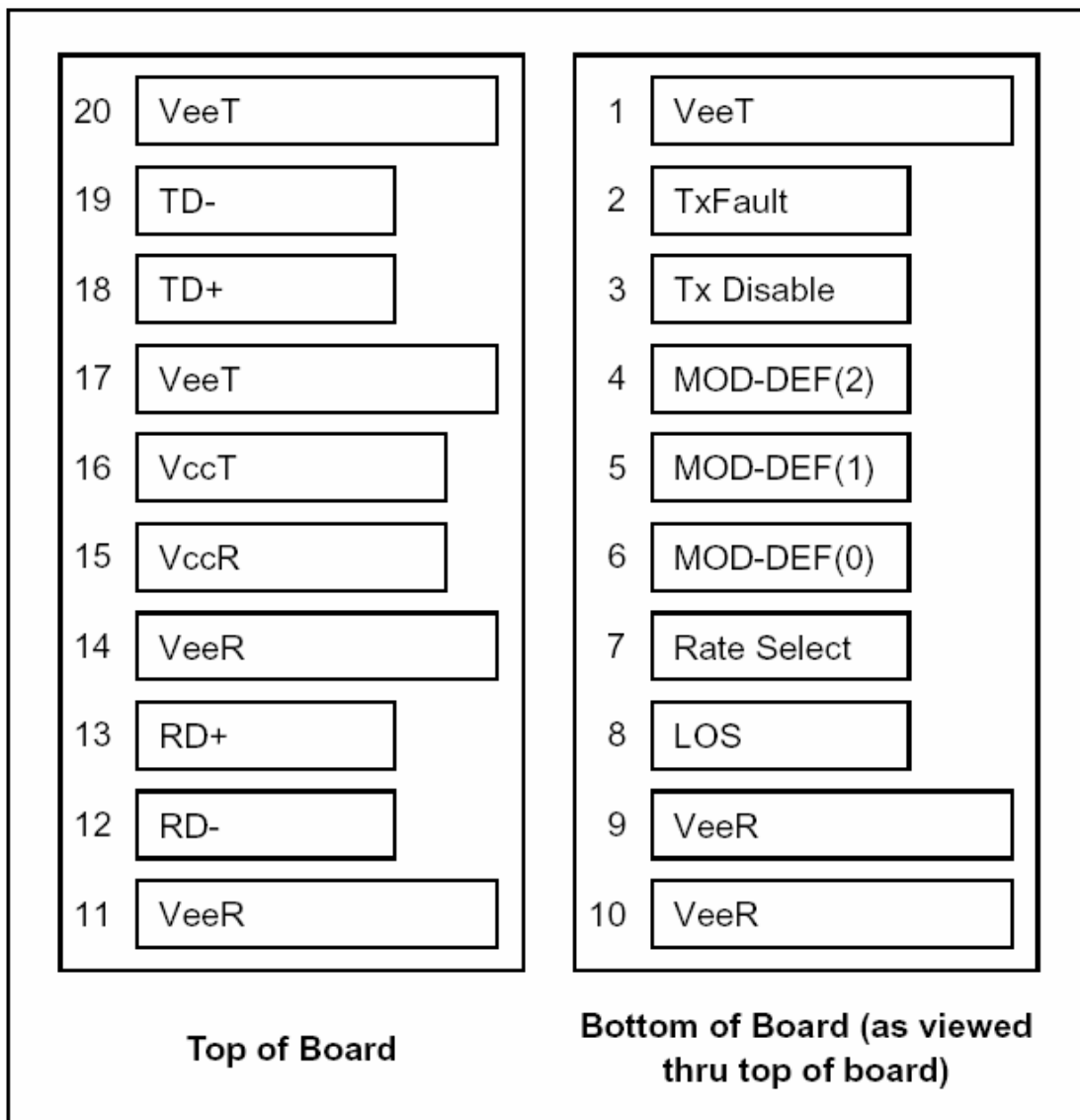

Table 5.Pin Function Definitions

Pin#	Name	Description	Notes
1	VeeT	Transmitter Ground	-
2	TX Fault	Transmitter Fault Indication	Notes 1
3	TX Disable	Transmitter Disable	Note 2, Module disables on high or open
4	MOD-DEF2	Module Definition 2	Note3, 2 wire serial ID interface
5	MOD-DEF1	Module Definition 1	Note 3, 2 wire serial ID interface
6	MOD-DEF0	Module Definition 0	Note 3, Grounded in Module
7	Rate Select	Not use	-
8	LOS	Loss of Signal	Notes 4
9	VeeR	Receiver Ground	Note 5
10	VeeR	Receiver Ground	Note 5
11	VeeR	Receiver Ground	Note 5
12	RD-	Inv. Received Data Out	Notes 6
13	RD+	Receiver Data out	Notes 6
14	VeeR	Receiver Ground	Note 5
15	VccR	Receiver Power	Note 7, 3.3V± 5%
16	VccT	Transmitter Power	Note 7, 3.3V± 5%
17	VeeT	Transmitter Ground	Note 5
18	TD+	Transmit Data In	Note 8
19	TD-	Inv. Transmit Data In	Notes 8
20	VeeT	Transmitter Ground	Notes 5

Note:

- TX Fault is an open collector/drain output, which should be pulled up with a 4.7K–10K Ω resistor on the host board. Pull up voltage between 2.0V and VccT, R+0.3V. When high, output indicates a laser fault of some kind. Low indicates normal operation. In the low state, the output will be pulled to < 0.8V.**
- TX disable is an input that is used to shut down the transmitter optical output. It is pulled up within the module with a 4.7–10 K Ω resistor. Its states are:**
 - Low (0 – 0.8V): Transmitter on**
 - (>0.8, < 2.0V): Undefined**
 - High (2.0 – 3.465V): Transmitter Disabled**
 - Open: Transmitter Disabled**

3. **Mod-Def 0,1,2.** These are the module definition pins. They should be pulled up with a 4.7K – 10K Ω resistor on the host board. The pull-up voltage shall be VccT or VccR. Mod-Def 0 is grounded by the module to indicate that the module is present Mod-Def 1 is the clock line of two wire serial interface for serial ID Mod-Def 2 is the data line of two wire serial interface for serial ID
4. **LOS (Loss of Signal)** is an open collector/drain output, which should be pulled up with a 4.7K – 10K Ω resistor. Pull up voltage between 2.0V and VccT, R+0.3V. When high, this output indicates the received optical power is below the worst-case receiver sensitivity(as defined by the standard in use). Low indicates normal operation. In the low state, the output will be pulled to < 0.8V.
5. **VeeR and VeeT** may be internally connected within the SFP module.
6. **RD-/+:** These are the differential receiver outputs. They are AC coupled 100 Ω differential lines which should be terminated with 100 Ω (differential) at the user SERDES. The AC coupling is done inside the module and is thus not required on the host board.
7. **VccR and VccT** are the receiver and transmitter power supplies. They are defined as 3.3V \pm 5% at the SFP connector pin. Maximum supply current is 300mA. Recommended host board power supply filtering is shown below. Inductors with DC resistance of less than 1 Ω should be used in order to maintain the required voltage at the SFP input pin with 3.3V supply voltage. When the recommended supply filtering network is used, hotplugging of the SFP transceiver module will result in an inrush current of no more than 30 mA greater than the steady state value. VccR and VccT may be internally connected within the SFP transceiver module.
8. **TD-/+:** These are the differential transmitter inputs. They are AC-coupled, differential lines with 100 Ω differential termination inside the module. The AC coupling is done inside the module and is thus not required on the host board.

Table 6.Diagnostics Specification

Parameter	Range	Unit	Accuracy	Calibration
Temperature	0 to +70	$^{\circ}$ C	\pm 3	Internal / External
	-40 to +85			
Voltage	3.0 to 3.6	V	\pm 3%	Internal / External
Bias Current	0 to 100	mA	\pm 10%	Internal / External
TX Power	-2 to +3	dBm	\pm 3	Internal / External
RX Power	-24 to -3	dBm	\pm 3	Internal / External

Package information

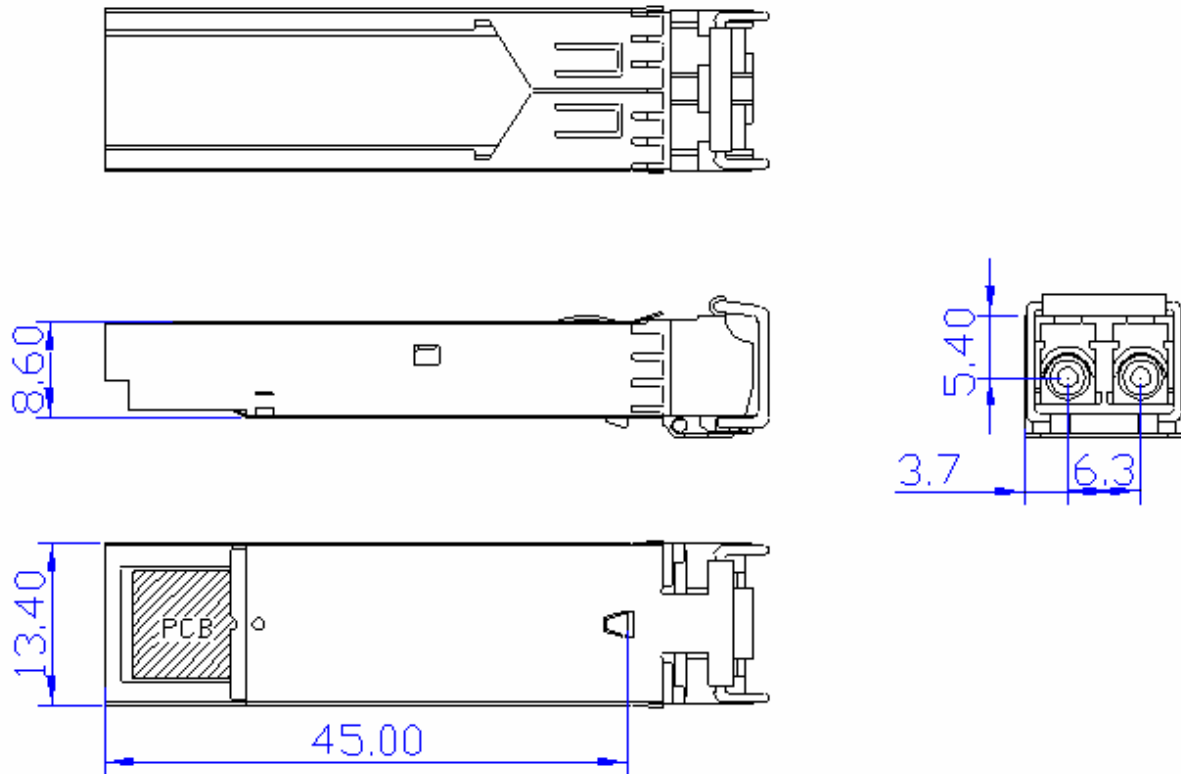

|

Unit: mm

Recommended Circuit

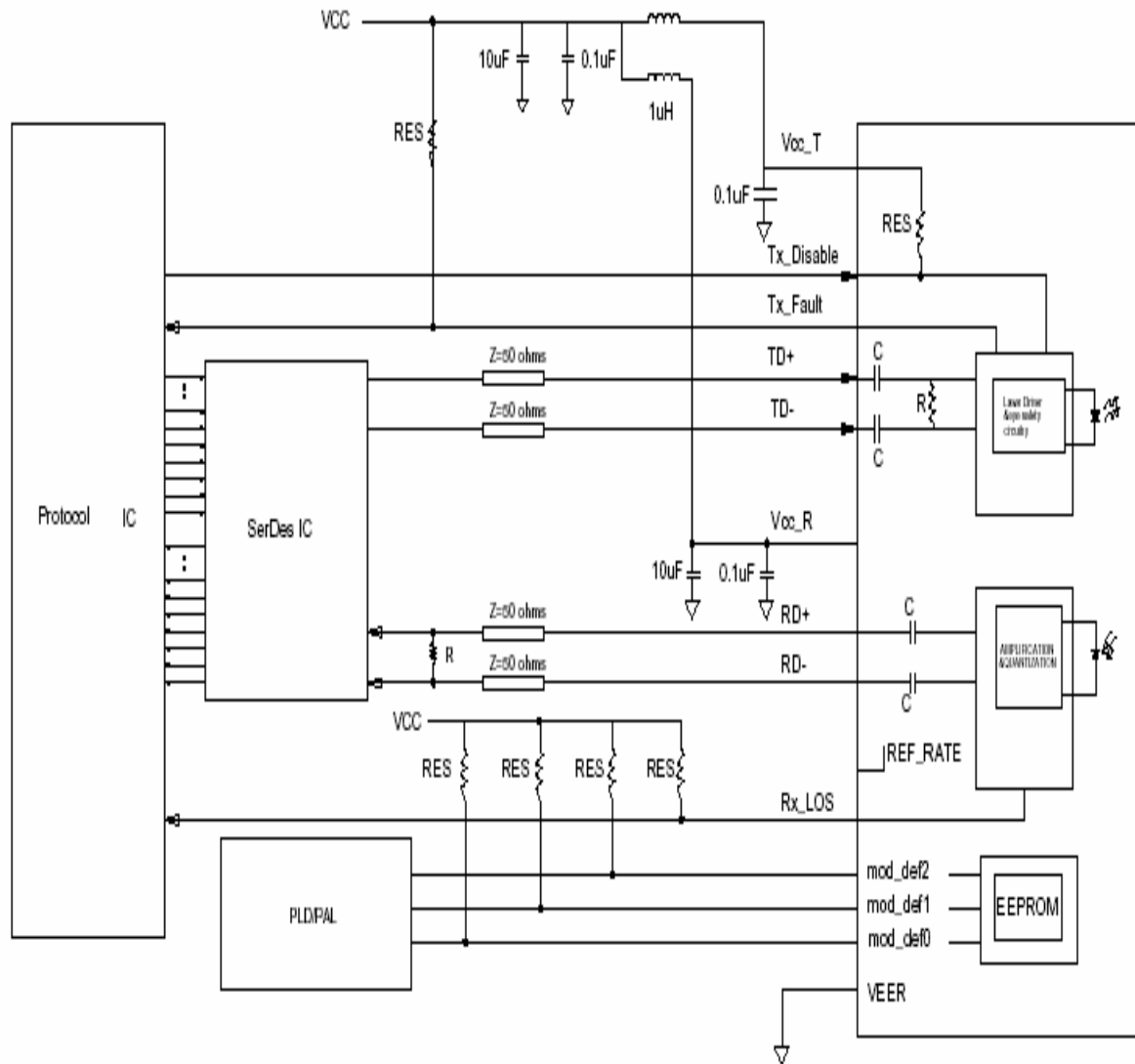

Note: 4.7K ohms < RES < 10K ohms

Recommended Board Layout Hole Pattern

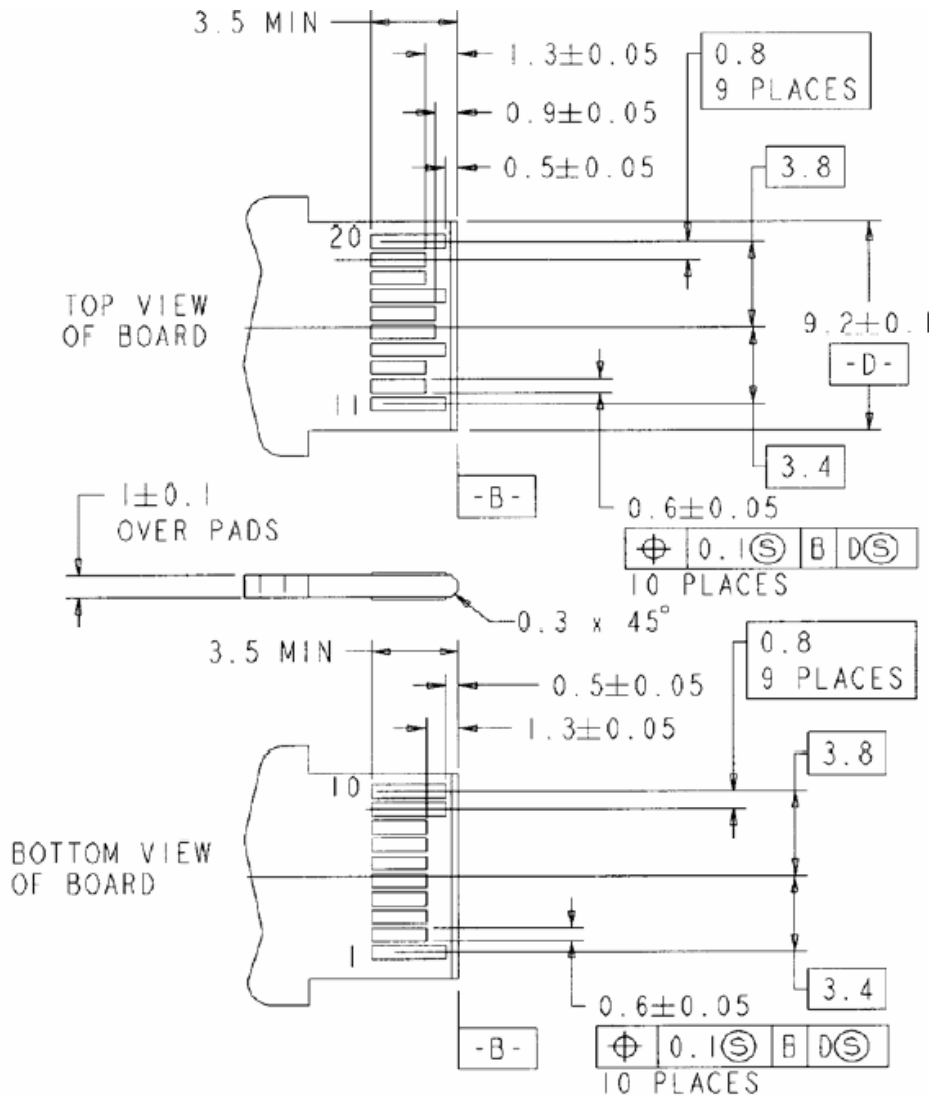

Obtaining Document

Please visit our website:

Http://www.staropto.com

SCFP XX 6 1 - 3 3 - 1 2 5 F

Wave length (nm)	Data Rate (Mb/s)	Package Type	Output power (dBm)	Operation Voltage (V)	Operation Temperature (°C)	Data/ Alarm Interface	Connector
27:1270	6:	1:	3:	3:	1:	2:	5:
29:1290	2500	With DDM	-2~+3	3.3	0~70	Data: PECL Alarm: TTL	LC/PC
31:1310							
33:1330							
35:1350							
37:1370							
39:1390							
41:1410							
43:1430							
45:1450							
47:1470							
49:1490							
51:1510							
53:1530							
55:1550:							
57:1570							
59:1590							
61:1610							